

---

## NOTICE OF NON-COMPLIANT SWIMMING POOL

A swimming pool inspection was conducted at the below premises, at the request of the pool owner, as required by S 22C of the *Swimming Pools Act 1992* (The Act).

S 22D of the Act requires the accredited certifier to issue a Certificate of Compliance, where the swimming pool complies with the requirements of this Part.

Where a swimming pool does not comply, S 22E of the Act requires the accredited certifier to issue a written notice to the owner of the swimming pool, providing reasons why the pool does not comply and the steps that need to be taken in order to achieve compliance.

This swimming pool was found to be non-compliant. The following written notice provides detailed information regarding those areas of non-compliance.

### 1. NOTICE INFORMATION

Date of notice:	<b>26<sup>th</sup> July 2023</b>
Date of inspection:	<b>26<sup>th</sup> July 2023</b>
Accredited Certifier name:	<b>Bradley Cooper (iComply Pool Safety Certification)</b>
Accreditation number:	<b>BDC 2604</b>

### 2. CLIENT INFORMATION:

Contact person:	<b>Stephanie Ahmad – First National Epping</b>
Pool owner:	<b>N &amp; J Hooymans</b>
Telephone contact:	<b>9686 5333</b>
Email:	<b>repairs@firstnationalepping.com.au</b>

### 3. LOCATION OF THE SWIMMING POOL:

Street address:	174 Cresthaven Ave
Suburb:	Bateau Bay
Local Government Area:	Central Coast

### AUSTRALIAN STANDARDS INFORMATION:

Commencing 1 May 2013, a new Standard was introduced to NSW for swimming pool compliance. This Standard is the AS 1926.1-2012.

However, if a swimming pool existed prior to this Standard being introduced, the swimming pool can continue to comply with the Standard that existed at the time the swimming pool was built, but only upon satisfying the following conditions:

1. Documentary evidence can be provided that demonstrates what pool barrier was existing and in place on 31<sup>st</sup> August 2008 (i.e. a photo)
2. Documentary evidence can be provided that shows that the pool barrier was fully compliant on the 31<sup>st</sup> August 2008 (i.e. a certificate of compliance)

Unless both of these conditions are met, the pool barrier must be assessed against the current Australian Standard (AS 1926.1-2012).

The exemptions under AS 1926-(1986) primarily related to the use of child-safe/child-resistant doors being used as part of a pool barrier, and 1200mm high boundary fence barriers, both of which the current Australian Standard does not allow.

Barrier exemptions also no longer apply if the pool barrier is substantially altered or rebuilt, not properly maintained, fenced voluntarily or non-compliant with the original standard at the time of inspection. The pool must then comply with the standard current at the time of the alteration, or alternatively, the current Australian Standard.

### POOL SAFETY INSPECTION:

The pool safety inspection was conducted in accordance with the requirements of AS 1926.1-2012 (the latest Australian Standard).

The pool barrier at the time of the inspection was found to be non-compliant.

The following areas of non-compliance were found:



**Issue:**

AS 1926.1-2012 (2.4.3) Gate Hinges

*Gate hinges shall not be permitted within the 900mm non-climbable zones unless they are located 900mm apart (measured from the top of each hinges).*

**The gate hinges are less than 900mm apart.**

**Recommendation:**

**Reposition gate hinges so they are minimum of 900mm apart (measured from the top of each hinge).**



**Issue:**

Section 17 Swimming Pools Act – Warning notices

*A warning notice must be displayed in a prominent position, bear the notice required by the regulations and be & be legible from a distance of 3 metres.*

**There is no CPR chart on display.**

**Recommendation:**

**Install an approved sign.**



**Issue:**

AS 1926.1-2012 (2.1) General

*The height of a barrier within the property shall be not less than 1200mm on the outside of the barrier.*

**The fence is less than 1200mm high along the grass section due to a build up of ground level.**

**Recommendation:**

**Reduce height of finished ground level within 500mm of the bottom of the fence, or increase height of fence.**





Issue:

AS 1926.1-2012 (2.2.4) Boundary barriers

Where a boundary fence acts as a barrier to a pool, it shall have a height of not less than 1800mm on the **inside**.

The boundary fence is less than 1800mm in height on the inside.

Recommendation:

Increase height of boundary fence to 1800mm measured on the inside (ensuring that any fence extension is deemed non-climbable and is compliant).

**Note:**

***It is often very difficult to fully explain situations, problems, access difficulties and rectification recommendations, or their importance, in a manner that is readily understandable by the reader.***

***Should you require clarification on any issue, or have any difficulty in understanding anything contained within this report, please do not hesitate to contact the inspector on 0412 339 982 prior to acting on this report.***

**IMPORTANT INFORMATION:**

The matters identified during this inspection do not pose a significant risk to public safety.

Where an accredited certifier is of the opinion that the swimming pool poses a significant risk to public safety, a copy of this notice will be forwarded immediately to the local authority for the area in which the swimming pool is situated.

**A pool owner is required under S 22E of the *Swimming Pool Act 1992* to make arrangements to rectify the non-compliant areas identified in this notice, & contact a Certifier within 6 weeks to arrange for a re-inspection. Where a Certificate of Compliance is not issued to the pool owner within that time, a copy of this notice must be forwarded to the local authority within 5 days after the end of the 6 week period.**

Please do not hesitate to contact us should you have any questions or require further advice regarding this notice. We look forward to assisting you in obtaining your Certificate of Compliance.

Bradley Cooper

Accredited Certifier Name (BDC 2604)

*Brad Cooper*

Signature

**NON-CLIMBABLE ZONES (Internal Fence):**

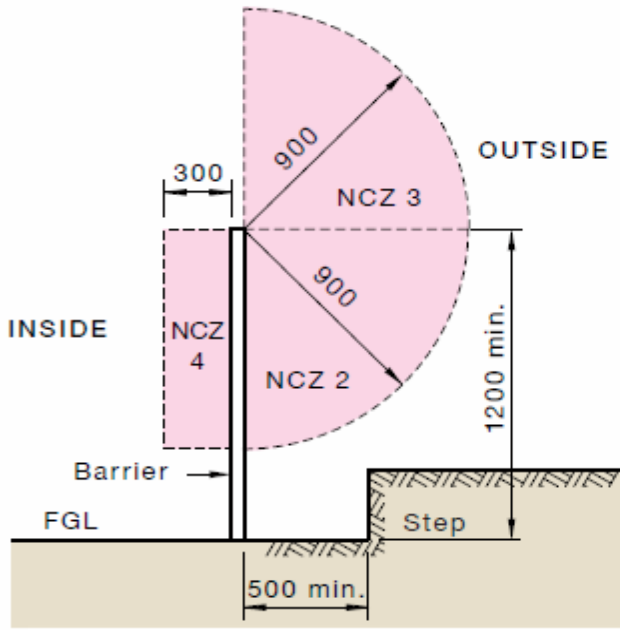

(a) NCZ 2 at top of barrier

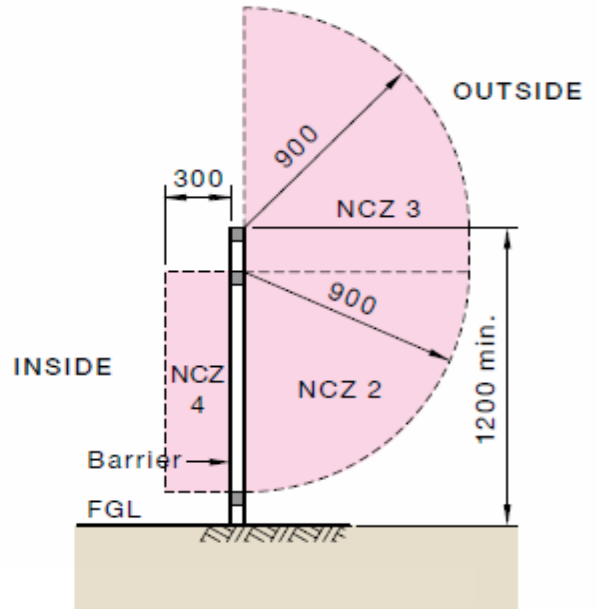

(b) NCZ 2 in middle of barrier

DIMENSIONS IN MM

**NON-CLIMBABLE ZONES (Boundary Fence):**

**AS 1926.1 – 2012**

Clause 2.2.4

**Boundary Barrier** clause 2.2.4

- Height not less than 1800mm
- NCZ 5 is formed by a 900mm radius down from top, on the inside (pool side) of the barrier

**Clause 2.3.1 Features and objects near a Barrier**  
 In addition to clause 2.2 (NCZ) steps, retaining walls, objects or level changes shall be sets 500mm to maintain the integrity of barrier required height.

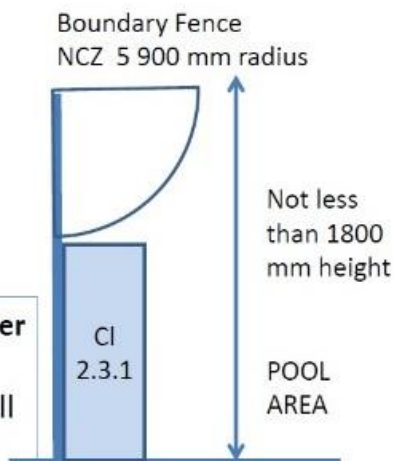

**NON-CLIMBABLE ZONES (Boundary Fence):**

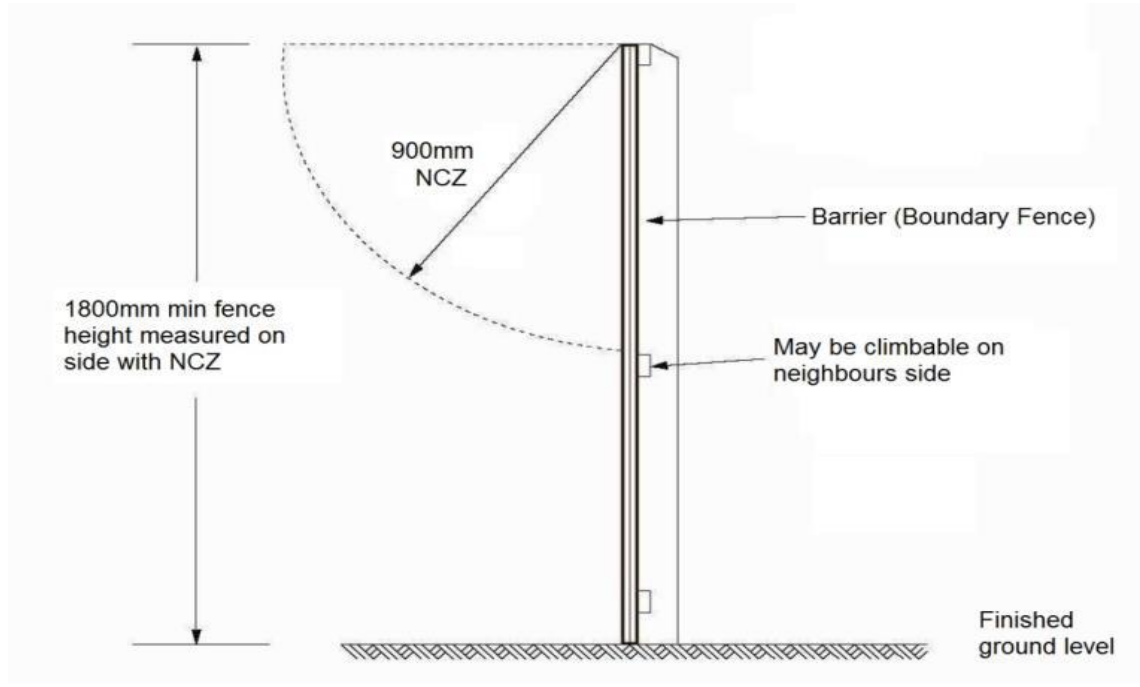

**MINIMUM & MAXIMUM SPACINGS:**

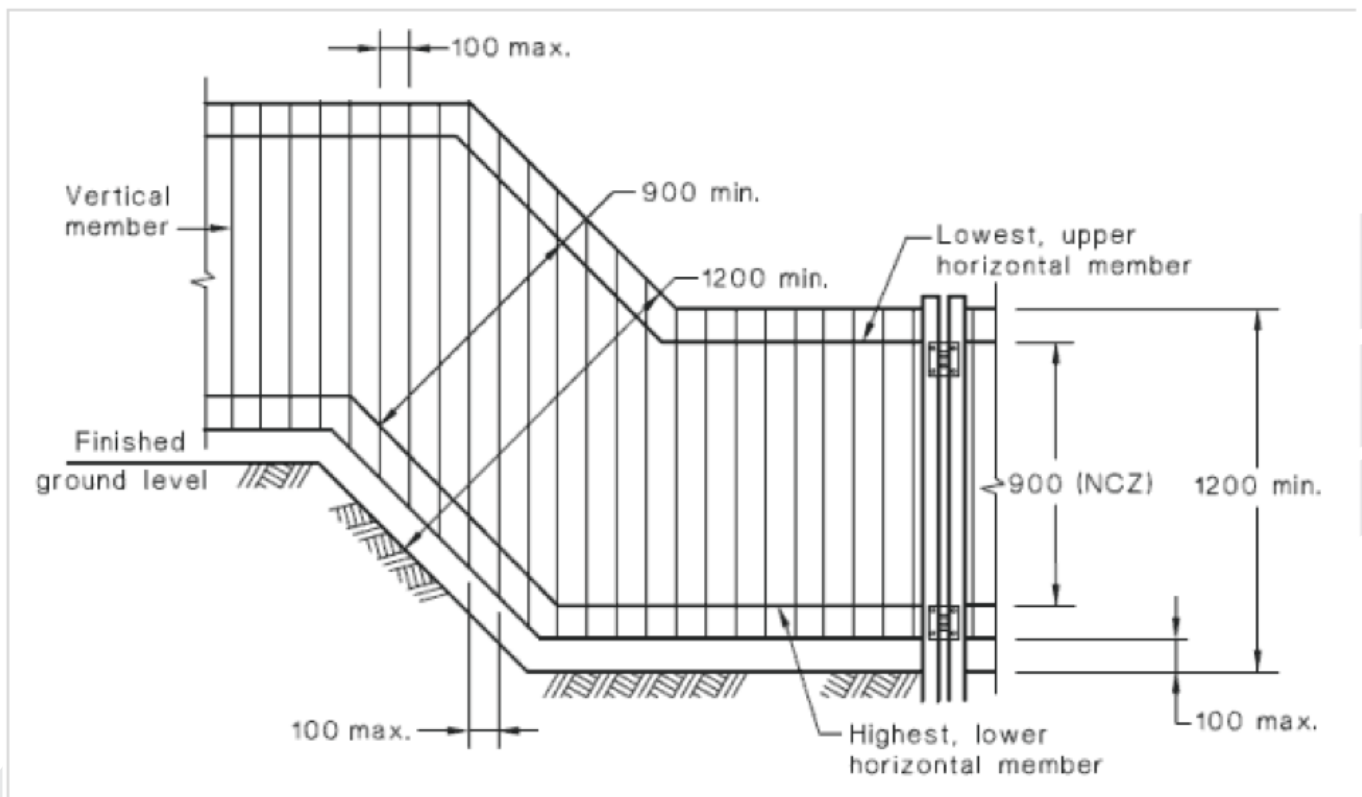

## **TERMS AND CONDITIONS**

The inspection was carried out in accordance with Australian Standards & Regulations and the Swimming Pools Act.

Any person who relies upon the contents of this report does so acknowledging the following clauses that define the Scope and Limitations of the inspection and form an integral part of the report. If there is anything contained within this report that is not clear or you have difficulty understanding, please contact the inspector prior to acting on this report.

### **The Purpose of the Inspection:**

The purpose of the Swimming Pool Inspection is to conduct an inspection of the pool barrier in order to issue either a Certificate of Compliance or a Notice of Non-Compliance. This Notice of Non-Compliance is to provide advice to the Pool owner regarding the non-compliance of the swimming pool barrier, identifying the non-compliant issues and providing recommendations on how to make the pool barrier compliant with the Australian Standard.

### **The Scope of the Inspection:**

The inspection comprises a visual assessment of the pool barrier, as well as conducting several tests for the strength & rigidity of the barrier and its components in accordance with the Australian Standard. The scope includes the measuring of all barrier components to ensure compliance with the Australian Standard & to form an opinion regarding the general condition of the fencing at the time of the inspection. An estimate of the cost of rectification of defects is outside the scope of the Standard & therefore does not form part of this report.

### **Limitations:**

This report is limited to a visual inspection of areas where safe and reasonable access is available and access permitted on the date and at the time of the inspection.